



**CANADIAN AUTOMOBILE SPORT CLUBS
ONTARIO REGION**

Appendix O, Section D - Formula 2000

Effective January 15, 2021

This page intentionally left blank

DRAFT



Appendix O, Section D - Formula 2000

© All material in this document is strictly the copyright of CASC Ontario Region and may not be reproduced without prior written permission.

These regulations are intended to assist in the conduct of Competitions and to further general safety. They are a guide and in no way guarantee against injury or death to participants, spectators or others. No express or implied warranties of safety or fitness for a particular purpose shall be intended or result from publication or compliance with these regulations. By applying for a competition licence and/or by entering a competition event, all participants are deemed to have understood and accepted these terms, including that motorsport is inherently dangerous and it is each participant's obligation to meet and maintain compliance with all regulations to reduce the risk of death or injury to self or others, recognizing that such risk is inherent to the sport and cannot be completely eliminated.

Red bold, italics text indicates significant changes or amendments.

CANADIAN AUTOMOBILE SPORT CLUBS ONTARIO REGION

1110 Finch Avenue West
Suite 222
North York, ON
M3J 2T2
CANADA

Tel: (416) 667 9500
Fax: (416) 667 9555
Toll-Free In Canada: (877) 667-9505

office@casc.on.ca
<http://casc.on.ca/>

Contents

1	DEFINITION	5
2	GENERAL CONSTRUCTION RESTRICTIONS	5
3	CHASSIS/FRAME	5
4	BODYWORK	6
5	CONTROL OF UNDERSIDES SHAPING.....	7
6	AERODYNAMIC AIDS.....	8
7	SUSPENSION	8
8	BRAKES	9
9	STEERING	9
10	WHEELS	9
11	ENGINES – PINTO/CAPRI	9
12	ENGINES - ZETEC.....	13
13	FORMULA 2000 DIMENSIONS.....	15
14	WEIGHT	16

DRAFT

APPENDIX O, SECTION D - FORMULA 2000

1 DEFINITION

- 1.1.1 Formula 2000 is a single-seat, open wheel racing car utilizing the Ford Zetec ZX3 twin cam 2 litre engine OR the Ford 2 litre single cam NE series engine OR the Ford Pinto/Capri 1971-74 single cam 2 litre engine.
- 1.1.2 Cars shall comply with the CASC-OR GCR and Race Regulations as well as the Regulations herein.
- 1.1.3 There shall be two groups of cars designated F2000A and F2000B.
 - a) F2000A: utilizing the Ford Zetec ZX3 2 litre dual overhead camshaft engine
 - b) F2000B: utilizing the Ford 2 litre single overhead camshaft NE series engine OR the 1971-74 Pinto/Capri 2 litre single overhead cam engine.

2 GENERAL CONSTRUCTION RESTRICTIONS

NOTE: Contained herein are the 1986 Formula 2000 chassis construction requirements. All new Formula 2000 cars are to be built to these specifications.

- a) Titanium, boron, beryllium, lithium-aluminum alloys, and metal matrix composites are prohibited.
- b) Composite materials containing fibers with a tensile modulus in excess of 100 GPa (this definition includes carbon fiber, Kevlar, Zylon, and Dyneema) are prohibited unless specifically permitted.
- c) Fuel Capacity: Maximum capacity 41 litres (10.83 gallons)
- d) Refer to section 13.0 Formula 2000 Dimensions for general dimensional limitations.

3 CHASSIS/FRAME

- 3.1.1 The chassis shall be of steel space frame construction. Monocoque-type structures are prohibited.
- 3.1.2 The soles of the driver's feet shall not extend beyond the front edge of the wheel rims in normal position (i.e., pedals not depressed) and shall remain behind the front bulkhead. The lower main frame rails shall be a minimum of 25 cm (9.8 inches) apart (inside dimension) from the front bulkhead to the main roll hoop.
- 3.1.3 Forward-facing braces that protect the driver's legs and feet shall extend from the front roll hoop to the front bulkhead. (The front bulkhead is defined as the transverse section of the frame immediately ahead of the pedals and drivers feet.) This does not preclude a secondary forward bulkhead ahead of this "front" bulkhead. This secondary bulkhead may be constructed from aluminum plate.
- 3.1.4 A stress bearing floor pan constructed from a minimum of 1.5 mm (0.060 inch) heat-treated aluminum sheet or 18-gauge steel sheet is required. At a minimum, it shall extend from the front bulkhead to the main roll hoop bulkhead. Its curvature shall not exceed 25.4 mm (1.0 inch). This floor pan may be constructed in multiple sections.
- 3.1.5 The front bulkhead, forward roll hoop (dash hoop) bulkhead and main hoop bulkhead may also utilize stress-bearing panels. No other stress-bearing panels are allowed.
- 3.1.6 Stress-Bearing Panel Definition: Any sheet material that is attached to the frame by welding, bonding, riveting, threaded fasteners, or any combination thereof, the centers of which are located closer than 15 cm (6 inches). The distance between fasteners is measured on the surface of the panels. No materials other than aluminum or sheet steel are allowed for use as stress-bearing panels. Stabilized materials (honeycomb) are not permitted as stress-bearing panels.

3.1.7 The area between the upper and lower main frame tubes from the front roll hoop bulkhead to the main roll hoop bulkhead shall be protected by at least one of the following methods to prevent the intrusion of objects into the cockpit. Panels may extend forward to the secondary bulkhead (Section 3.1.3) and aft to the front face of the engine to protect the fuel cell.

- a) Panel(s), minimum of either 1.5 mm (0.060 inch) heat treated aluminum (6061-T6 or equivalent) or 18-gauge steel, attached to the outside of the main frame tubes.
- b) Reinforced body consisting of at least two layers of 5-ounce, bi-directional, laminated Kevlar material incorporated into the body, which shall be securely fastened to the frame. (5 or more layers are highly recommended.)
- c) Composite panels attached to the outside of the main frame tubes. These panels shall be at least 1.5 mm (0.060 inch) in thickness and at least as strong as 1.5 mm (0.060 inch) 6061-T6 aluminum. They may be constructed from any material including those defined in Section 2 b).

For any of these methods, panels may not be attached to the frame with fasteners closer than 15 cm (6 inch) centers measured along the surface of the panel. The steel tubes used for the chassis braces in this area shall be at least equivalent to the roll hoop brace material.

3.1.8 The engine, bell housing/oil tank and gearbox are permitted to be stressed and/or load bearing. Bell housings and gearbox housings shall be metal.

3.1.9 A firewall(s) that seals the drivers' compartment (cockpit) and the engine compartment is required. Forward facing ducts may be installed to deliver air directly to the engine compartment. Air duct openings may be located within the cockpit provided the firewall is extended to prevent the passage of flame and debris from reaching the driver.

3.1.10 Brackets for mounting components, such as the engine, transmission, suspension pickups, instruments, clutch and brake components, and body panels may be made from any material not prohibited in Section 2 b).

3.1.11 All formula cars shall have a front impact attenuation device meeting at least one of the following criteria.

- a) An FIA-approved front impact attenuation structure.
- b) A metallic structure, securely attached to the front bulkhead, with a minimum cross section of 200 sq cm (31 sq in.), 40 cm (15.75 in.) forward of the clutch and brake pedals (not depressed), constructed of a minimum of 18 gauge 6061-T4 or equivalent aluminum.
- c) A non-metallic composite structure, securely attached to the front bulkhead or incorporated into the nose piece, with a minimum cross section of 200 sq cm (31 sq in.), 40 cm (15.75 in.) forward of the clutch and brake pedals (not depressed), constructed of a minimum of 6 mm stabilized (e.g., honeycomb) material with inner and outer reinforcements of a minimum of 2 5-ounce laminate material (fiberglass, carbon, Kevlar, and so on).
- d) Radiators may be incorporated in impact attenuation structures.
- e) Composite impact attenuation structures may incorporate carbon and/or Kevlar regardless of any class restrictions on materials.

3.1.12 No engine oil or water tubes are allowed within the cockpit, except for shielded (stainless steel braid) mechanical oil pressure lines. Chassis tubes shall not be used as oil or water transport tubes.

3.1.13 Fuel cell vents shall be located at least 25 cm (9.8 inches) to the rear of the cockpit.

4 BODYWORK

For the purposes of this section, bodywork includes all panels external to the chassis/frame and licked directly by the air stream. This includes panels above or below the floor pan and the bottoms of any side pods.

4.1.1 The bodywork opening giving access to the cockpit shall have the following minimum dimensions:

- Length: 60 cm (23.62 inches)
- Width: 45 cm (17.72 inches)

This width extends over a length of 30 cm (11.81 inches) minimum. This minimum rectangular opening may exist anywhere forward of the firewall. Forward-facing roll bar/cage bracing and padding will not be considered in these dimensions.

- 4.1.2 The driver's seat shall be capable of being entered without the manipulation or removal of any part or panel, with the exception of the steering wheel and/or drivers head surround. The steering wheel and the surround shall be removable by the driver and/or safety workers without the use of any tools. Readily legible removal instructions for safety workers are recommended. Bead seats are recommended.
- 4.1.3 Bodywork, rear spoiler(s) and any attached components except for suspension components shall not exceed a maximum width of 95 cm (37.4 inches). No part of the bodywork, rear spoiler, or exhaust system shall extend more than 80 cm (31.5 inches) behind the centerline of the rear axle nor exceed in height a horizontal plane 90 cm (35.4 inches) above the ground with the car as qualified or raced with the driver on board. The safety roll bar/roll cage and engine air box are not included in these restrictions. Allowances shall be made for radius of bodywork along primarily horizontal surfaces in this area. Under trays and floor pans may extend laterally past cockpit sides, side-pods, and engine compartment enclosures, but only up to the 95 cm (37.4 inches) maximum allowed width.
- 4.1.4 Diffusers and under trays shall not exceed a maximum width of 95 cm (37.4 inches). No part of the diffuser or undertray shall extend more than 80 cm (31.5 inches) behind the centerline of the rear axle nor exceed in height a horizontal plane 90cm (35.4 inches) above the ground with the car as qualified or raced with the driver on board.
- 4.1.5 Carbon fiber may be used for cockpit interior panels, radiator ducts, air intakes and mirrors. The cockpit is defined as that space inside the bodywork from the main roll hoop forward to the front bulkhead. Cockpit interior panels may not be attached to the frame with fasteners closer than 15 cm (6 inches) centers measured along the surface of the panel.
- 4.1.6 Kevlar may be used for reinforcement of any bodywork.

5 CONTROL OF UNDERSIDES SHAPING

It is the intent of these rules to minimize (not eliminate) the use of "ground effects."

- 5.1.1 A reference area is defined as:

The full width of the lowest surfaces of the car licked by the air stream between the rear edge of the front tires and the front edge of the rear tires.

These surfaces may include the floor pan, undertray, diffuser, side pod bottoms and any essentially horizontal bodywork that is included in the lowest surfaces licked by the air stream. Within this reference area, the lowest surfaces licked by the air stream shall be flat with a total vertical tolerance of 2.5 cm (1.0 inch). An undertray beneath the engine, bell housing and/ or gearbox is not required.

- Mirrors and any primarily vertical bodywork (for example, cockpit or radiator sides) that are oriented 45 degrees or greater relative to the ground may extend laterally past the outer edges of the floor pan and/or undertray and are not subject to these reference area restrictions.
- Fairings for streamlining suspension pickups are not subject to these reference area restrictions but shall be symmetrical about their horizontal axis.
- The perimeter of any reference area surface that transitions upward to any bodywork may use a maximum 2.5 cm (1.0 inch) radius and shall be included in the reference surface measurement.

- 5.1.2 Measurement for compliance of the defined area shall be performed as follows:

- a) A non-flexible straight-edge bar shall be placed against the lower surface of the reference area in a suitable section (unworn and flat enough to prevent rocking of the bar) from which the bar can be oriented to measure all parts of the reference area. The competitor shall be responsible for the availability and condition of such a surface. The bar shall be of sufficient length to reach all portions of the reference area from that surface.
 - b) All measurements shall be taken vertically from the bar to the reference area surfaces. The total maximum vertical distance (additive upward and downward) from the bar to any part of the reference area surfaces shall be 2.5 cm (1.0 inch). Skid blocks and or rub strips are not included in this measurement.
- 5.1.3 No aerodynamic devices, for example, venturi tunnels, skirts, body sides, skid planks, under trays, skid blocks, etc., may extend more than 1 cm (0.4 inches) below the reference area.

An example of venturi tunnels is shown in the following figure.

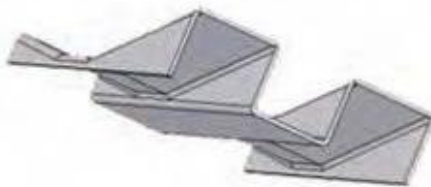

6 AERODYNAMIC AIDS

- 6.1.1 A wing shall be defined as any shape that has a leading edge and a trailing edge and creates down force.
- 6.1.2 Both front and rear wings are a requirement for F2000. See Section 13 Formula 2000 Dimensions. Cockpit or remote adjustment is not permitted. Wings and airfoils shall not be adjusted while the car is in motion.
- 6.1.3 Any part of the car which that has an influence on the aerodynamic stability of the vehicle shall be firmly attached with no provisions for adjustment to vary down force while the car is in motion.
- 6.1.4 It is not permitted to duct air through any part of the bodywork for the purpose of aerodynamic down force. There shall be no forward-facing gaps or openings in or about the bodywork with the exception of those necessary for engine cooling, engine air inlet, shock, or brake cooling. All ducted air for heat exchangers shall pass through those heat exchangers. Front and rear wing assemblies are allowed gaps between wing elements.
- 6.1.5 Primarily vertical (see Section 5.1.1 a) air diverters greater than 30 inches forward of the main hoop (i.e. "bargeboards") that stand away from the cockpit sides and are attached to (or through) the cockpit sides, under trays and/or side-pods are prohibited.
- 6.1.6 Diffuser under trays to the maximum allowed bodywork width are permitted, but any portion within the reference area (see Section 5) shall comply with the reference area measurement rules.
- 6.1.7 Wings, endplates and their attachment(s) may incorporate Kevlar reinforcement.

7 SUSPENSION

Suspension is defined as the system of springs, shock absorbers, control arms, links, etc., supporting the vehicle on its wheels. Anti-roll bars, anti-roll bar links, and steering components are not considered as suspension in this section and are unrestricted.

- 7.1.1 All suspension components shall be of steel or ferrous material, with the exception of hubs, hub adapters, hub carriers, bell cranks, pivot blocks, bearings, bushings, spring caps, abutment nuts, shock absorber caps and nuts, which may be of aluminum alloy.

- 7.1.2 Front and rear hub carriers shall be only steel, aluminum or magnesium alloy for cars manufactured after January 1, 1983.
- 7.1.3 Springs shall be steel only.
- 7.1.4 Control arms and all associated items that attach directly to the chassis members shall be boxed in or captured to prevent intrusion into the cockpit. "Anti-intrusion" bars are highly recommended on front suspension arms.
- 7.1.5 Shock absorber design is unrestricted but casing material shall be steel or aluminum alloy.
- 7.1.6 It is not permitted to attach spoilers, fairings or other devices that may exert down force to movable suspension members. If the suspension member is of streamline or airfoil cross section, it shall be symmetrical about its horizontal axis. Brake lines may be attached to suspension members and may be enclosed in a symmetrical fairing.

8 BRAKES

- 8.1.1 Unrestricted, except:
- a) Calipers shall be ferrous or aluminum alloy with no more than 4 pistons.
 - b) Brake rotors shall be ferrous.

9 STEERING

Unrestricted.

10 WHEELS

- 10.1.1 Wheels are unrestricted except that:
- a) Material shall be metal.
 - b) Diameter shall be thirteen (13) inches.
 - c) Rim width shall not exceed 6.0 inches front and 8.0 inches rear.
 - d) All measurements shall be taken between the beads.

11 ENGINES – PINTO/CAPRI

- 11.1.1 The Ford 2 litre single overhead camshaft "NE" series engine and the 1971-74 Pinto/Capri 2 litre single overhead camshaft engine shall conform to the following specifications. The nominal bore is 90.84mm and the nominal stroke is 76.95mm (Note: All blocks shall contain casting number HM6015BA, HM6015AA, HM6015BB, HM6015AB, HM6015DA, or HM6015AD. Dashes in the casting number are not relevant.). Production tolerances are permitted providing the total swept volume does not exceed 2000cc.
- 11.1.2 The rockers shall remain entirely unmodified. Alternate manufacturers may be used as long as the original materials and dimensions are the same. Camshafts shall be from Ford Motor Company, or Crower part #E57553 FF2000, or any camshaft that is a replica of the original and of the same material may be used. Camshaft geometry shall be stock. An alternate optional camshaft, Elgin part number 2000FC, may be used only in the original iron head. Regrinding camshaft lobes is permitted as long as the camshaft lobe center is $112^\circ \pm 2^\circ$. Offset keys are permitted. Tuftriding or Parkerizing is permitted. Maximum valve lift at determined points by camshaft rotation will be established. The use of a low rate substitute valve spring is permitted. Load characteristics of special checking spring: twelve (12) lbs., at 1.417 inches, thirty (30) lbs., at 1.000 inches. An adjustable camshaft sprocket which retains the same number of teeth and pitch as the stock sprocket may be used.

- 11.1.3 A standard crankshaft shall be used or any crankshaft that is a replica of the original crankshaft and of the same material may be used. Spot machining to achieve balance is permitted. Tuftriding, Parkerizing, shot peening, shot blasting, and polishing are permitted. Minimum weight: twenty-seven point five (27.5) lbs.
- 11.1.4 The flywheel shall be a standard component or the approved alternate Elite-001. The minimum weight is 10.5 lbs. with ring gear. The flywheel may be machined to achieve minimum weight. Spot machining to achieve balance is permitted. Flywheel bolts are free and locating dowels are permitted. A 1600 GT starter ring may be fitted. The use of any single plate clutch is permitted provided no modification is made to the flywheel other than changing the points of attachment of the clutch to the flywheel. Carbon fiber clutches are not permitted.
- 11.1.5 Maximum compression ratio will be controlled as follows:
- Minimum Cylinder Head combustion chamber volume 49cc (not including head gasket). Polishing and/or tooling of the cylinder head to achieve only the required combustion chamber volume is permitted.
 - Standard Ford gasket, Fel-Pro #8361PT, or Ferrea part number G50100 may be used. Gaskets will have a minimum thickness of 0.9mm, minimum diameter of cylinder aperture of 92mm.
 - Pistons shall not protrude above cylinder block surface at TDC.
- 11.1.6 It is permissible to reshape inlet and exhaust port by removal of metal within limits. Addition of material in any form is prohibited. Maximum diameter of inlet port at manifold head face 39.5mm. Maximum dimensions of exhaust port at manifold face 35.5mm x 27mm. The distance between the valve centers and the angles of the valves shall not be altered.
- 11.1.7 Pistons shall be standard Ford Mahle, AE Hepolite, CP, or J&E. Pistons shall be unmodified in any way except for balancing and as detailed herein.

The following combinations are permitted:

- Mahle piston P/N 80HM6102LA with rings, pin, connecting rod (with bolts), but without bearings. Minimum permitted weight = 1332.5 grams.
- Mahle piston P/N 85HM6102DA with rings, pin, connecting rod (with bolts), but without bearings: Minimum permitted weight = 1240 grams.
- AE Hepolite piston P/N 21426, casting P/N 21426 (AE Hepolite) with rings, pin, connecting rod (with bolts), but without bearings: Minimum permitted weight = 1240 grams.
- CP piston P/N IV 2.0 LTR with rings, pin, connecting rod (with bolts), but without bearings: Minimum permitted weight = 1240 grams. Part number and Ivey logo stamped on gudgeon pin bosses.
- JE piston P/N M-6102-B200 with rings, pin, connecting rod (with bolts), but without bearings: Minimum permitted weight = 1240 grams.

NOTE: M-6102-B200 piston assembly is now made by JE and is visually different. I.D. Marks: M-6102-B200, Ford racing logo. All marks pin stamped on gudgeon pin bosses.

- 11.1.8 Rings are unrestricted provided that:

- One oil control and two compression rings are used.
- No modification is made to the piston for the installation of the rings.

Localized machining of the gudgeon pin bosses to achieve balance and weight by simple machining; all external surfaces, dimensions, and profiles shall remain standard with the exception of the top surface of the piston crown which may have simple machining to achieve balance.

11.1.9 11.9 Valves may be of Ford manufacture or Ferrea part numbers VSOIN200 and VSOEX2000. Valves shall remain standard; no reprofiling or polishing is permitted.

- a) The original forty-five (45) degree seat angle shall be maintained.
- b) Maximum face diameter inlet 42.2mm.
- c) Maximum face diameter exhaust 36.2mm.
- d) Maximum valve stem diameter 8.4mm.

11.1.10 Full connecting rods may be standard Ford, Cosworth, Oliver, or Crower. The approved Crower part numbers are SP93230B-4 or SP93230PF-4. Any rod bolts may be used. Floating piston pins may be used. Standard rod length shall be 5.00 inches (+0.005" -0.010"). Machining is permitted to remove metal from the balancing bosses to achieve balance only. Tuftriding, Parkerizing, shot peening, shot blasting, polishing, etc., are permitted.

11.1.11 Maximum valve lift against cam angle with zero tappet clearance: (Lift measured in mm)

Standard Cam	Intake		Exhaust	
Angle	Opening	Closing	Opening	Closing
0	10.442	10.442	10.442	10.442
5	10.36	10.36	10.36	10.36
10	10.11	10.11	10.11	10.11
15	9.69	9.69	9.69	9.69
20	9.11	9.11	9.11	9.11
25	8.37	8.37	8.37	8.37
30	7.45	7.45	7.45	7.45
35	6.38	6.38	6.38	6.38
40	5.17	5.17	5.17	5.17
45	3.86	3.86	3.86	3.86
50	2.59	2.58	2.58	2.59
55	1.50	1.47	1.47	1.50
60	0.86	0.81	0.81	0.86
65	0.65	0.56	0.56	0.65
70	0.54	0.43	0.43	0.54
75	0.46	0.33	0.33	0.46
80	0.37	0.19	0.19	0.37
85	0.26	0.08	0.08	0.26
90	0.20	0.01	0.01	0.20
Alternate Cam	Intake		Exhaust	
Angle	Opening	Closing	Opening	Closing
0	11.182	11.182	10.149	10.149
5	11.102	11.092	10.07	10.071
10	10.853	10.821	9.831	9.829
15	10.423	10.363	9.426	9.415
20	9.821	9.721	8.854	8.826
25	9.069	8.916	8.117	8.073
30	8.177	7.955	7.205	7.154
35	7.131	6.85	6.132	6.071
40	5.960	5.624	4.920	4.866
45	4.702	4.313	3.611	3.600
50	3.425	3.010	2.346	2.380
55	2.242	1.851	1.325	1.406
60	1.278	0.994	0.722	0.825
65	0.642	0.509	0.488	0.604
70	0.334	0.307	0.385	0.524
75	0.215	0.208	0.303	0.461
80	0.134	0.130	0.224	0.404
85	0.064	0.063	0.146	0.343
90	0.022	0.024	0.090	0.279

11.1.12 Engines will be mounted upright and aligned fore and aft in the chassis.

11.1.13 A single carburetor only will be used on a standard inlet manifold. The carburetor will be a Weber 32/36 DGV 26/27mm venturi, its origin being from a 1600 GT "Kent" or 2000 SOHC NE engine.

The Holly 5200 32/36 carburetor also may be used; carburetor with the swaged fuel inlet fitting shall have this fitting replaced by drilling and tapping the carburetor body for a threaded fitting. The air cleaner may be removed and a trumpet fitted, the jets may be changed, both throttles may open together, cold start devices and diffused bar may be removed, internal and external anti-surge pipes may be fitted, and seals on emission control carburetors may be removed. The bottom of the lower column portion of the auxiliary venturi may be machined for purposes of high-speed enrichment. No other modifications are permitted. Chokes (venturi) shall remain standard and no polishing or profiling is permitted.

11.1.14 The addition of material by any means to any component is prohibited.

11.1.15 It is permitted, as a means of repair, to replace damaged valve seats and cylinder bores by replacement cast iron valve seat inserts and cast-iron cylinder liners; valve guides may be replaced with cast iron or bronze, all to standard dimensions. Repairs to the cam towers to facilitate replacement of cam bearing and/or replacements of broken or cracked towers are permitted as long as the cam bearing center line is not changed and that one original cam tower is retained. Line boring of cam bearing caps is permitted.

11.1.16 Balancing of reciprocating and rotating parts is permitted only by removal of metal from locations so provided by the manufacturer.

11.1.17 Non-standard rocker covers are permitted providing they in no way improve the performance of the engine.

11.1.18 Standard valve spring retainers shall be used, and single valve springs only are permitted. Shims are permitted, and valve springs are otherwise free.

11.1.19 Exhaust system and manifold are unrestricted.

11.1.20 Lubrication system is unrestricted; dry sump is permitted. Localized machining of the cylinder block is permitted to allow fitting of the oil pump.

11.1.21 Oil coolers are unrestricted.

11.1.22 Cooling system: Unrestricted. The radiator, if housed in or incorporating a cowl air-scoop deflector, shall comply with body regulations.

11.1.23 Fuel Pump: Unrestricted.

11.1.24 Distributors are unrestricted providing they retain the original drive and location. The distributor is defined as the component which triggers the L.T. current and distributes the H.T. current. The Ignition Timing may only be varied by vacuum and/or mechanical means. It is prohibited to use any other method or component to trigger, distribute, or time the ignition.

11.1.25 Only the standard inlet manifold shall be used.

The ports may be reshaped by the removal of metal as long as the following dimensions are maintained: maximum size at head face = 1.437" (36.5mm), maximum size at carburetor flange = 3.405" (86.5mm) x 1.595" (40.5mm). The carburetor seat face may be machined to horizontal in the fore to aft plane. The diameter of the ports may exceed the above listed dimensions if the casting bore is untouched and in its original state. The water passages in the inlet manifold may be plugged. Holes in the inlet manifold resulting from the removal of emission/vacuum lines shall be plugged.

11.1.26 Gaskets and seals are unrestricted except for the cylinder head gasket that has the requirements listed in Section 11.1.5b and the intake gasket. The intake gasket thickness shall not exceed 1.1mm. Intake gasket is not to be construed as a spacer.

11.1.27 Pump, fan, and generator drive pulleys are unrestricted.

11.1.28 The crankcase breather may be altered or removed, but all breathers shall discharge into a catch tank.

- 11.1.29 Mechanical tachometer drives may be fitted.
- 11.1.30 Generators are optional.
- 11.1.31 Standard oversize and undersize bearings are permitted. This does not allow reducing the bearing surface area by reducing the width of standard bearings.
- 11.1.32 The use of non-standard replacement fasteners (nuts, bolts, screws, studs, and washers) which are not connected with or which do not support the intake manifold or any moving parts of the engine is permitted.
- 11.1.33 Only modifications or additions specifically covered by these regulations are permitted. All engine components not covered by these regulations shall remain completely standard and unmodified. When a system is specified to be "unrestricted" (e.g. Sections 11.1.21 and 11.1.23), the restrictions of this paragraph do not apply.
- 11.1.34 The use of the Fast Forward aluminum cylinder head is permitted. The following dimensions shall be maintained.
- a) Intake port maximum volume 70.0 cc. Exhaust port maximum volume 52.0 cc.
 - b) Intake port surface to exhaust port surface 5.580 +/- 0.020 inches Intake valve center line to (adjacent) intake valve center line 4.015 +/- 0.015 inches
 - c) Exhaust valve center line to (adjacent) exhaust valve center line 4.015 +/- 0.015 inches
 - d) The machine tool marks in the intake and exhaust ports shall remain untouched for 0.750 inches from the respective gasket surfaces.
- 11.1.35 Any spark plugs may be used.
- 11.1.36 Engines shall be mounted upright and aligned longitudinally fore and aft in the chassis.

12 ENGINES - ZETEC

- 12.1.1 The Ford Zetec ZX3 engine shall conform to the following specifications and may be modified only as specifically allowed. If these specifications do not explicitly allow a modification, then it may not be done. The philosophy of the Zetec engine in F2000 is to allow limited engine rebuilds but no performance modifications to the engine. Blue printing, balancing, head porting, polishing, etc. are strictly prohibited and against the spirit of the Zetec formula. Where Ford part numbers are specified, normal industry part number supersession is expected, and the superseding part numbers are automatically included.
- 12.1.2 Only the Ford #RFYS4E6090AC or RFYS4E6090AD head is allowed. The cylinder head may not be ported or polished. Machining the cylinder head is not permitted except as specified in these rules. The head may not be surfaced or milled beyond the minimum thickness of 5.230" measured between the cam cover seating surface and the lower plane of the head.

The camshaft, valves, springs, and shim/bucket components shall be original Ford parts and may not be modified in any way. Only original unmodified Ford parts may be used for direct replacement. The camshafts shall remain as ground by Ford; no polishing is permitted.

A standard three-angle "production" valve job is required and the only allowed angles are those defined in the Ford factory manual. The intake valve seats shall be 30° 45° 70° with the 45° face a minimum 1.5 mm wide. The exhaust valve seats shall be 30° 45° 55° with the 45° seat 1.5 mm wide minimum. Valve seats may not be replaced.

The only allowed camshafts are the Ford #L913B YSAA intake and #L913B C2B exhaust. The original, unmodified Ford camshaft and crankshaft timing pulleys shall be used. Required camshaft timings are as follows:

- Intake centerline 116 - 117 degrees ATDC
- Exhaust centerline 106 - 107 degrees BTDC

- 12.1.3 Pistons, crankshaft, and rods may be replaced only with standard original Ford replacement parts. The crankshaft may be ground or polished for the purpose of installing oversize main or rod bearings.

The rod journals shall remain stock and the rods may not be bored or remanufactured in any way. The rod and crankshaft bearings may be replaced only with original or oversized Ford bearings.

The required original crankshaft main bearing journal dimension is 2.282 - 2.283 inches and the required original crankshaft rod journal dimension is 1.846 - 1.847 inches. The corresponding main journal dimensions for oversized bearings are either 2.273 - 2.274 inches or 2.263 - 2.264 inches; the corresponding rod journal dimensions for oversized bearings are either 1.837 - 1.838 inches or 1.827 - 1.828 inches.

The crankshaft centerline to deck dimension is 8.378 inches and may not be altered. The main bearing housing bore is 2.452 - 2.453 inches and the rod housing bore is 1.9642 - 1.9650 inches. Only original Ford rod bolts with a minimum weight of 24.6 grams or ARP rod bolts with a minimum weight of 23.5 grams may be used.

- 12.1.4 Only original stock Ford replacement piston rings may be used. The ring end gaps may not be altered and shall remain as manufactured by Ford. All of the rings shall be installed including the complete oil scraper assembly. The piston bore may be honed solely to allow piston ring seating. The first and second compression rings shall be installed in the positions designated by Ford.
- 12.1.5 All surfaces on the head, block, rods, pistons, and crankshaft shall remain as manufactured by Ford and may not be altered in any way. The original casting marks and cast surfaces shall remain as-cast and also meet all of the Ford design values and tolerances as stated in the Ford factory manual or as delineated in these specifications.
- The block may not be decked. Only Ford Zetec ZX3 blocks with block numbers #RFYS4G6015AA, or #RFYS4G6015AD or #RFYS4G6015AE are permitted. The required compression ratio is 9.6:1, the required standard bore is 3.3390 - 3.3410 inches and the required stroke is 3.461 inches. The maximum bore dimension of 3.3410 inch is intended to allow for cylinder wear only. It is not permitted to machine to this dimension. This measurement will be taken 0.250 below the block deck where the bore is untouched by the piston ring.
- 12.1.6 Flywheel: The minimum weight is 8.0 lbs. and any weight removal from the specified flywheel shall come from the clutch plate surface. Only the Quarter Master #QM107160 flywheel may be used.
- 12.1.7 Any 7¼ inch single plate or double plate, non-carbon fiber clutch is allowed.
- 12.1.8 Any oil pan is allowed. The oil pan may not contain an oil scraper between the oil pan and the block. No device in the oil pan may be contoured to the crankshaft assembly to function as an oil scraper nor may any device be closer to the rotating crankshaft assembly than 0.5 inches.
- 12.1.9 Any three-stage oil pump with a maximum of two scavenge stages is allowed. The maximum scavenge rotor dimensions are 1.600 inches in diameter and 1.375 inches in length. The minimum pressure rotor dimensions are 1.600 inches in diameter and 0.863 inches in length.
- 12.1.10 The exhaust system manifold tubing OD shall be 1.5 inches and the manifold tubes shall be a minimum of 24 inches in length and shall terminate into a single exhaust pipe through a 4 into 1 collector. The collector angles shall be the standard 15 degree bend, (30 degree included angle) with an exit diameter of 2 inches. The tail pipe shall be a minimum of 24 inches in length. The tail pipe includes a muffler, if present, as long as the inlet and outlet pipes of the muffler are the same diameter as the tail pipe. 4 into 2 into 1 exhaust collectors or reduced diameter venturi sections are prohibited.
- 12.1.11 ECU: The Pectel T2 unit is required. The current "F2kCS" map should be used and is available on the F2kCS web site.
- 12.1.12 Intake manifold and fuel injection components: The Quicksilver Race Engines (QSRE) intake air scoop, intake manifold, throttle bodies, air horns, fuel rail and injector system are required and shall be used with no modifications of any kind. The only allowed intake manifold and throttle body combination is the #0138 manifold available through QSRE. Only stock Ford fuel injectors may be used, and they may not be modified in any way. Fuel injectors may be replaced only with stock Ford injector part number #0280155887 XS4U-AA.

- 12.1.13 Intake restrictor: The QSRE #1975 intake restrictor shall be used. It shall not be modified in any way. The new restrictor internal diameter is 1.340 inches and this value cannot be exceeded in any measurement of the diameter. The restrictor port centerlines or shape may not be altered.
- 12.1.14 Engines shall be mounted upright and aligned longitudinally fore and aft in the chassis.
- 12.1.15 The addition of material by any means to any component is prohibited
- 12.1.16 Non-standard rocker covers are permitted providing they in no way improve the performance of the engine.
- 12.1.17 Oil coolers are unrestricted.
- 12.1.18 A liquid cooling system is mandatory, but radiator and water pump are unrestricted.
- 12.1.19 Fuel pump is unrestricted.
- 12.1.20 Gaskets and seals are unrestricted except for
 - a) cylinder head gasket, Ford part number XS7Z6051CA
 - b) a continuous O-ring of cross-section of 0.100 inches shall be fitted to each intake runner groove between the intake manifold and the head which is to ensure that no air by-passes the O-ring seal
- 12.1.21 Pump, fan, and generator drive pulleys are unrestricted.
- 12.1.22 The use of non-standard replacement fasteners (nuts, bolts, screws, studs, and washers) which are not connected with or which do not support the intake manifold or any moving parts of the engine are permitted.
- 12.1.23 Any spark plugs may be used.

13 FORMULA 2000 DIMENSIONS

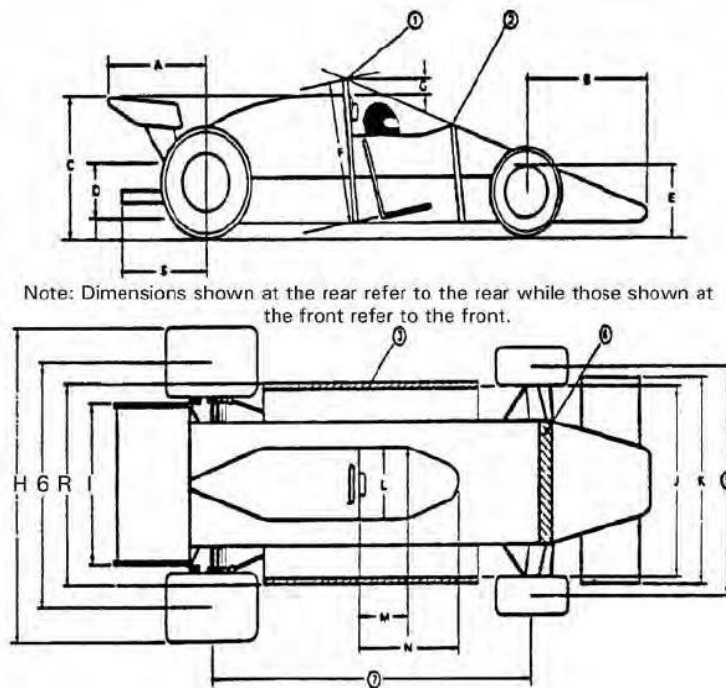

Dimension (refer to drawing)	Measurement (cm)
A. Maximum rear overhang from rear wheel axis	80

Dimension (refer to drawing)	Measurement (cm)
B. Maximum front overhang from front wheel axis	100
C. Maximum height measured from the ground	90
D. Exhaust height measured from the ground	20 - 60
E. Maximum height of any aerodynamic device	Rim height
F. Minimum safety rollover bar height in line with driver's spine	92
G. Minimum allowed helmet clearance	5
H. Maximum overall width	185
K. Maximum nose width	135
L. Minimum cockpit opening	45
M. Minimum cockpit parallel opening length	30
N. Minimum cockpit overall opening length	60
R. Maximum body width behind front wheels	95
S. Maximum exhaust length from rear wheel axis	80
7. Minimum wheelbase	200
5. Minimum track	120

14 WEIGHT

14.1.1 Minimum weight as practiced, qualified or raced, with driver and required safety equipment is 1225 lbs.