



**Canadian Automobile Sports Club
Ontario Region**

2024 Drivers Meeting

April 21, 2024



Agenda

- Opening Remarks and Introductions
- New Classes
- Sponsors
- Technical Changes
- Executive Steward
- Administrative Items



CASC Positions

- Pat Cyr, Race Director
- Mike Nilson, Chief Scrutineer
- Chris Lawson, Chief Instructor
- Richard Muise, Exec Steward
- Ted Michalos, President CASC-OR
- Jennifer Di Francesco, CASC Admin
- Sam Parsons, Social Media
- Chelsea Giffin, Social Media
- RaceDirector@casc.on.ca
- RaceTech@casc.on.ca
- RaceCoach@casc.on.ca
- Exec.Steward@casc.on.ca
- President@casc.on.ca
- Office@casc.on.ca



CASC Positions - Drivers Representatives

- GT1-GT2
- GT-3-GT5
- Formula Prototype Challenge
- Open Wheel
- Formula 1600
- Miata
- VARAC
- Female Drivers
- High Performance Driving Experience
- Daria Katchi
- Bruce Wiley & Robert Turner
- Steffen Rilli
- Phil Wang
- Brian Graham
- Matt Savini & Kevin Conte
- Dave Good
- Chelsea Giffin
- Will Switzer



mazda

Miata Canada Cup



The Miata Canada Cup is designed to provide a low cost entry into road racing.

- MCC1 - Series NA and NB cars (1990 to 2005)
 - MCC2 - Series NC cars (2006 to 2015)
 - MCCU - any other Miata/MX5
-
- DOT tires with 180 tread rating or higher (no slicks).
 - Technical questions contact our Chief Scrutineer, Mike Nilson



mazda

Miata Canada Cup



Too Many Mods

**Lots of
Possible
Track
Time**

MCC 1
(SM NA/NB)

MCC 2
(SMX NC)

MCC U
(Unlimited)

Vintage

GT

You can also run

Run, if you are feeling brave



High Performance Drivers Experience

- new run group for regional events
- hybrid between lapping/HPDE sessions and full blown W2W racing
- designed to provide a lower cost introduction to racing
- limited car prep, limited speeds, restricted passing zones
- goal is to attract non-racers to regional racing



Sponsorship

- \$71,750
 - \$51,000 direct to competitors
 - \$20,750 series costs
- TV production and 6 Event Shows and a Wrap Up Show
- \$6,000 Announcing Costs
- CASC Decals
- Media Coverage

- There are a LOT of sponsor decals!!!

Sponsors



- \$45,000
 - \$35,000 to competitors
 - \$10,000 to admin



- \$8,500
 - \$1,000 admin
 - \$7,500 direct to competitors
 - top three \$1,200, \$800, \$500

AUTOMOVES[®]

TV production



\$6,000 Announcing Costs



6 Event Shows and
a Wrap Up Show

POLITO
RACING

\$2,500

Sponsors

touchette.

M O T O R S P O R T

\$2,500



BRAIDAN

MOTORSPORT

\$2,500



\$2,000 random gas cards to random drivers not on the podium



THE DIFFERENCE IN BRAKING

\$2,500 Hard Charger



\$2,500 Hard Charger

Sponsors



\$1,500 for Rookie of the Year



\$1,250



RADICAL
CANADA EAST

\$1,000



product



media coverage



Scholarships and Awards

- Bob McCallum Scholarship
 - The Bob McCallum scholarship was established to provide financial assistance to first year Motorsport competitors in the 2024 CASC-OR Championship, competing in the F1200, Toyo F1600 or Formula Libre Championship series.
- Team Canada Scholarship
 - Yearly competition that is awarded to a deserving young Canadian driver.
 - Run under the auspices of Canadian motorsport veteran Brian Graham of Brian Graham Racing, the winner receives a fully funded drive at the prestigious Formula Ford Festival at Brands Hatch in England in late October.

Overview



Questions or Comments?

Scrutineering – Belt Installation

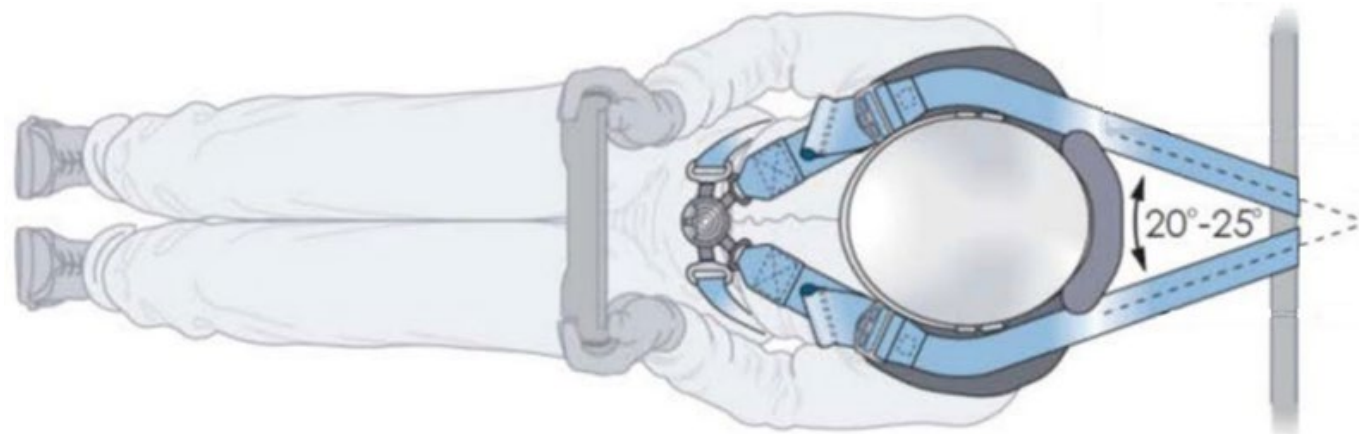
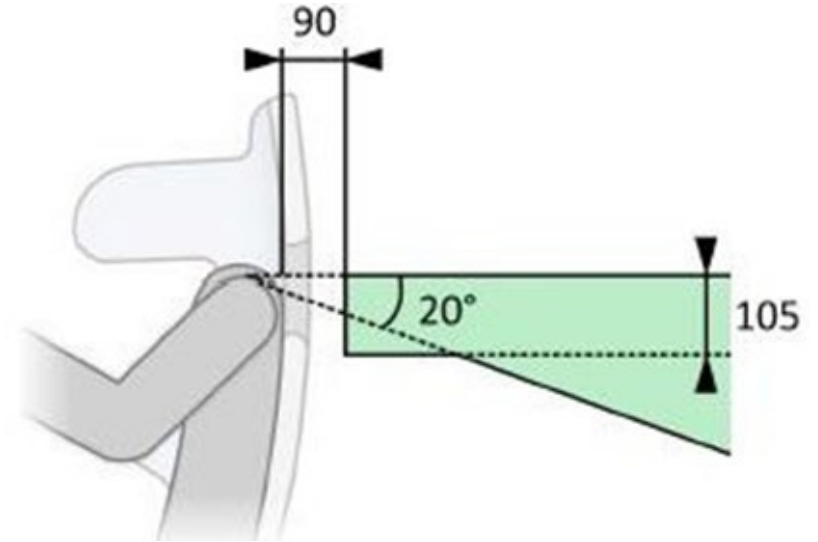
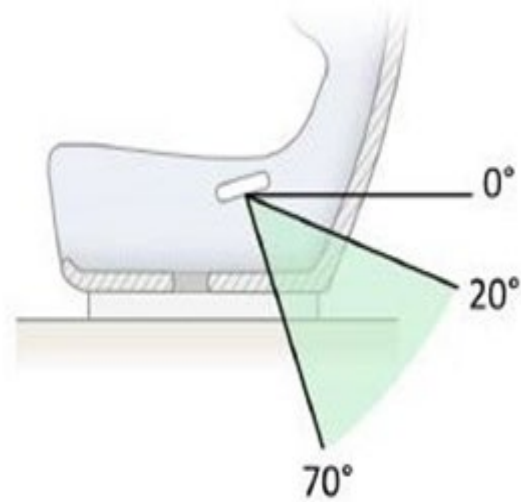
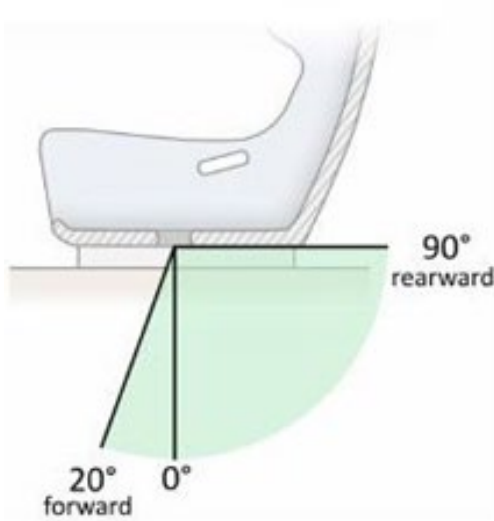

“following
Manufactures’
Instructions”
is not sufficient.

Scrutineering – Additional Items (1)

- Drivers' Restraints
 - FIA 8853/2016 are good until 5 years past the stated expiry date subject to annual inspection of the conditions of the belts
- Pirelli Tires may be purchased from Braiden and or Touchette
 - Competitors will need to retain proof of purchase for validations.
- Helmet stickers
 - Stickers will reflect their Snell standard (2015 or 2020)
 - Don't need to be inspected before the driver goes out, but cars may be impounded for inspection if the helmet does not have a sticker



Scrutineering – Additional Items (2)

- Probationary Licences
 - Drivers using a Probationary Licence shall have a 127mm orange triangle on a white background mounted as close as possible to the centreline of the rear of the car.
- Logbook Applications & “At Home” Inspections are available online
- Scrutineering Database
 - In MSREG and “My Garage” enter logbook, VIN, Year, Make, and Model of the car. If one doesn’t exist, leave blank (no N/A or TBD or 1234)
- Car/Driver History is available from 2013
 - Let us know if you would like a report for yourself or your car

Scrutineering



Questions or Comments?



Stewards - 2024 Regulations Changes

- VARAC Grids for Historic & Classic (2.11MJ or less). (RR2.2.2)
- Start / restart – passing may begin anywhere after start signal. (RR2.3.3; App H 3.1)
- Penalty for passes under yellow for qualifying, races.
 - Practice: Loss of 2 qualifying laps (RR2.1.1a)
 - Race: Added penalty to following grid as well. (R2.1.3a)
- Red flag – stop in pit lane unless otherwise directed. (App H 4.3)
- Exiting disabled car. (App H 7.11.4)
- Helmets, belts – Mike will cover in scrutineering slides. (App I)
- Miata Canada Cup (App O, Subsection B; App P)
- SMP Breakouts for Long Track (App O, Subsection F)
 - Changes based on Review Committee.
 - Pro Track – no changes, same as 2023, 2022, etc.



Stewards

- We are looking for new stewards for 2024.
- The Stewards are the officials responsible for the enforcement of the regulations, ensuring a fair and equitable competition for everyone.
- We are looking for passionate current or retired racers, team members, officials & volunteers, who want to use their experience to give back to the sport.
- We are looking for people who have good interpersonal and communications skills, a sound judgement and sense of fairness. We work as a team, sharing the responsibility and workload.
- Contact Exec.Steward@casc.on.ca.

Administrative Items

- Waivers
 - Different waivers are required for each track

- Shannonville Motorsports Park GT Sprint Breakouts
 - Pro Track
 - same as 2023
 - Long Track
 - GT1: 1m, 49.999s or faster
 - GT2: 1m, 50.000s or slower
 - GT3: 1m, 54.000s or slower
 - GT4: 1m, 58.000s or slower
 - GT5: 2m, 02.000s or slower

Schedule



Start	End	Event	track	Formula Libre	Pirelli Grand Touring	Pirelli Super Touring	Vintage Historic, CL4, CL5	Sedans/Modern Classic	Formula Prototype Challenge	Miata Canada Cup	Toyo Tires F1600	HPDE
27-Apr		Spring Fling	SMP	X	X	X	X	X	X	X	X	
4-May	5-May	BEMC Spring Trophy Races	CTMP	X	X	X	X	X	X			
18-May	19-May	Victoria Day Sprints	CTMP								X	
1-Jun	2-Jun	SMP Cup	SMP	X	X	X				X	X	X
14-Jun	16-Jun	VARAC Vintage Grand Prix	CTMP				X	X				
13-Jul		Peter Jackson	SMP				X					
27-Jul	28-Jul	BARC Canadian Touring Trophy Races	CTMP	X	X	X	X	X	X	X	X	
16-Aug	18-Aug	OSCC Calabogie Summer Classic	CMP	X	X	X	X		X	X	X	
21-Sep	22-Sep	BEMC Late Summer Trophy Races	CTMP	X	X	X	X	X			X	X
5-Oct	6-Oct	Celebration	CTMP	X	X	X	X	X	X	X		



Questions or Comments?